

# MDS

## LIQUID TURBINE FLOW METER

### USER MANUAL



# Introduction

This instruction manual is a guide material for the liquid turbine flowmeter, please do not use it on other models. The user who uses the liquid turbine flowmeter for the first time must read this manual carefully. It will also help the users who have used it to re-understand the knowledge and experience. Please read the content carefully and fully understand it before applying it in practice.

It is recommended that after the equipment starts to operate normally, this manual should be handed over to equipment operators and maintenance personnel for use, and the operation and production should be carried out according to the requirements of the manual.

The company will continue to research and improve the liquid turbine flowmeter products. The content of this manual may sometimes be different from the products and details purchased by the user. If the user has any questions about the purchased product or the content of the manual, please contact our company inquires.

**For your safety, please read the following safety warnings carefully before using the meter.**

1. The fluid will not corrode the meter body and the materials of wetted parts.
2. When measuring flammable liquids, take care to prevent fire or explosion.
3. When handling hazardous liquids, you must follow the manufacturer's safety practices.
4. When working in a dangerous environment, follow the correct operation steps.
5. When the turbine flowmeter is removed, it may cause liquid splashing. Please follow the safety operation specification of the fluid equipment manufacturer to prevent splashing.
6. Do not use compressed air to purge the turbine flowmeter.
7. Pay attention to the turbine blades inside the flowmeter, even small scratches or gaps will affect the accuracy.
8. In order to achieve the best results, the longest calibration period of the meter should not exceed 1 year.

# Catalog

<b>I Overview</b> .....	<b>1</b>
1.1 Applications.....	1
1.2 Working Principle.....	1
1.3 Product Structure.....	1
<b>II Flow Meter Types</b> .....	<b>2</b>
2.1 Converter.....	2
2.2 Sensor.....	2
<b>III Technical Parameters</b> .....	<b>2</b>
3.1 Applicable Medium.....	2
3.2 Nominal Diameter.....	2
3.3 Temperature.....	3
3.4 Power Supply.....	3
3.5 Output Signal.....	3
3.6 Flow Range.....	3
<b>IV Menu and Parameters</b> .....	<b>5</b>
4.1 Manual.....	5
4.2 Selection of Basic Parameters .....	5
4.2.1 Flow Rate.....	5
4.2.2 Total Flow .....	6
4.2.3 Calibration.....	6
4.2.4 Output.....	6
4.2.5 Communication.....	7
4.2.6 Factory Setup.....	7
4.3 Parameter Setting.....	8
4.3.1 Flow Rate.....	8
4.3.2 Total Flow.....	9
4.3.3 Calibration.....	9
4.3.4 Output.....	10
4.3.5 Communication.....	10
4.3.6 Factory Setup.....	11
<b>V Terminal Board Wiring Instructions</b> .....	<b>12</b>
5.1 Terminal Schematic.....	12
5.2 Terminal Board Wiring Instructions.....	12
<b>VI RS485 Mailing Address Table</b> .....	<b>13</b>
<b>VII Use and Adjustment</b> .....	<b>14</b>
6.1 Precautions.....	14
6.2 Installation Location.....	14
<b>VIII Malfunction Repair</b> .....	<b>15</b>
<b>VIII Ordering Instruction</b> .....	<b>16</b>

# I. Overview

## 1.1 Application

Turbine flowmeter is a precision flow measuring instrument that measures the flow and total volume of impurity-free and non-corrosive liquids. It is widely used in petroleum, chemical, metallurgy, scientific research and other fields.

## 1.2 Working principle

When the measured liquid flows through the sensor, the impeller rotates under the action of the fluid, and its speed is proportional to the average flow velocity of the pipeline. The rotation of the impeller periodically changes the magnetic resistance value of the magnetic circuit, and the magnetic flux in the detection coil changes periodically to generate an induced electromotive force with the same frequency as the blade rotation frequency. After being amplified, it is converted and processed.

## 1.3 Product structure

The basic structure of a turbine flowmeter is shown in Figure 1-1. It is mainly composed of a meter body, a front guide, a rear guide, an impeller, a signal connector, and a converter.

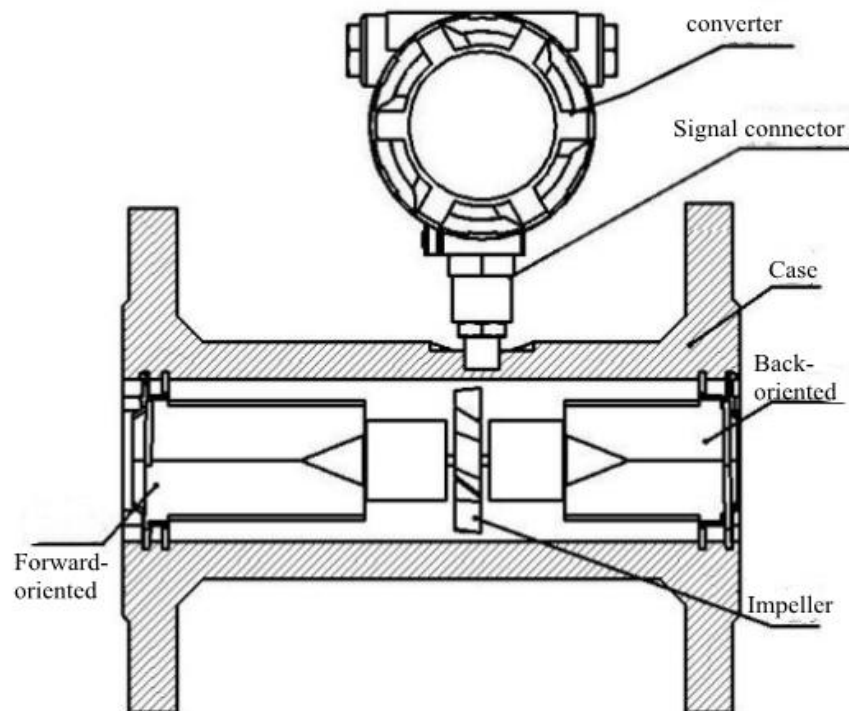









Figure 1-1 Flange turbine structure drawing

## II、Flow meter types

### 2.1 Converter

		
Pulse output type	Current output type	Intelligent display type

### 2.2 Sensor

		
Thread connection	Tri-clamp connection	Flange connection
		
Accessories: filter and straight pipe section	Accessories: clamp, chuck	

## III. Technical Parameters

### 3.1 Applicable medium

No impurities, low viscosity, no strong corrosive liquid.

### 3.2 Nominal diameter

Applicable caliber: Dn4-200mm

DN4-50mm (Thread connection)

DN4-100mm (tri-clamp connection)

Dn4-200mm (Flange connection)

### 3.3 Temperature

Ambient temperature: (-20~+60)°C

Relative humidity: 5%~90%

Atmospheric pressure: (86~106)kPa.

Medium temperature: (-20~+200) °C (Standard)

(-20~+130) °C. (customization)

### 3.4 Power supply

Main power: 24VDC

Battery-powered: 3.6V lithium battery.

### 3.5 Output signal

Pulse; 4 ~ 20 mA; RS485 Modbus protocol communication.

### 3.6 Flow range

Caliber (mm)	Flow range(m <sup>3</sup> /h)	Extended flow rangem <sup>3</sup> /h)
4	0.04~0.25	0.04~0.4
6	0.1~0.6	0.06~0.6
10	0.2~1.2	0.15~1.5
15	0.6~6	0.5~5
20	0.8~8	0.45~9
25	1~10	0.5~10
32	1.5~15	0.8~15
40	2~20	1~20
50	4~40	2~40
65	7~70	5~70
80	10~100	7~100
100	20~200	10~200
125	25~250	13~250
150	30~300	15~300
200	80~800	40~800
Accuracy	0.5 %	1.0%

# **LWGY Turbine Flow Converter**

## **Manual**

## IV. Menu and Parameters

### 4.1 Menu

FLOW RATE	TOTAL FLOW	CALIBRATION	OUTPUT	COMMUNICATION	FACTORY SETUP
PV Units	Total Units	Loop Out Zero	Signal output	Mode	Sensor Size
PV Decimal	Total Decimal	Loop Out Full	Pulse output	Baud rate	K-factor
Flow Range	Total Preset		Frequency output	Parity	Linearity
Cut Off				Device ID	Density
High Alarm					Language
Low Alarm					
Damping					

### 4.2 Selection of Basic Parameters

#### 4.2.1 FLOW RATE

1.1 PV Units	Selection: L/s L/m L/h m <sup>3</sup> /s m <sup>3</sup> /m <sup>3</sup> /h Nm <sup>3</sup> /s Nm <sup>3</sup> /m Nm <sup>3</sup> /h USG/s USG/mUSG/h kg/s kg/h t/s t/m t/h The default value is m <sup>3</sup> /h
1.2 PV Decimal	Select item: 0 1 2 3 The default value is 2
1.3 Flow Range	Floating points:99999999.00-0.00 m <sup>3</sup> /h The default value is 100.0 m <sup>3</sup> /h
1.4 Cut Off	Floating point:9.90 - 0.00 %. The default value is 0.0 %

1.5 High Alarm	Floating point:99.00 - 0.00 %. The default value is 100.0 percent
1.6 Low Alarm	Floating point:99.00 - 1.00 % The default value is 0.0 %
1.7 Damping	Floating points: 90.0 - 0.1 The default value is 1.0s

#### 4.2.2 TOTAL FLOW

2.1 Total Units	Select item: L m3 Nm3 USG kg t The default value is m3
2.2 Total Decimal	Select item: 0 1 2 3 The default value is 1
2.3 Total Preset	Floating points:999999999- 0.00 m3 When this value is set, the current total is overwritten by this setting value

Note: If the total amount shows "Over Flow! ", please deal with it in a timely manner (zeroing or preset) so as not to affect normal measurements.

#### 4.2.3 CALIBRATION

3.1 Loop Out Zero	Floating points: 5.0 - 3.0 The default value is 4.000mA
3.2 Loop Out Full	Floating points: 21.0 - 19.0 The default value is 20.000mA

#### 4.2.4, OUTPUT

4.1 Signal output	Signal output
4.2 Pulse output	Select item: High, low The default value is
4.3 Frequent output	Floating points: Max:5000-0.00 Hz The default value is 2000Hz

#### 4.2.5 CONMMUNICATION

5.1 Mode	Selection: RTU ASCII The default value is RTU
5.2 Baud rate	Select item: 9600 19200 38400 57600 The default value is 9600
5.3 Parity	Select item: NONE (no checks) ODD (parity) EVEN (parity). The default value is 8
5.4 Device ID	Number of words: 253 - 1 The default value is 001

Note: Please refer to the Turbine MODBUS User Manual for specific operation of the communication.

#### 4.2.6 FACTORY SETUP

Please enter our designated password 100000

6.1 Sensor Size	Select item :D N 9999-0000 m The default value is DN 0050 mm	
6.2 K-factor	Floating points: 99999999.9999 - 0000000.0000 The default value is 10000.0000	
6.3 Linearity	6.3. 1 Linear Correction 1	Floating points: 999999.9 - 000000.0Hz The default value is 0.0Hz Floating points: 999999.9999 - 000000.0000N/m3 The default value is 0.0000N/m3
	6.3. 2 Linear Correction 2	Floating points: 999999.9 - 000000.0Hz The default value is 0.0Hz Floating points: 999999.9999 - 000000.0000N/m3 The default value is 0.0000N/m3
	6.3. 3 Linear Correction 3	Floating points: 999999.9 - 000000.0Hz The default value is 0.0Hz Floating points: 999999.9999 - 000000.0000N/m3 The default value is 0.0000N/m3
	6.3. 4 Linear Correction 4	Floating points: 999999.9 - 000000.0Hz The default value is 0.0Hz Floating points: 999999.9999 - 000000.0000N/m3 The default value is 0.0000N/m3



	6.3. 5 Linear Correction 5	Floating points: 999999.9 - 000000.0Hz The default value is 0.0Hz Floating points: 999999.9999 - 000000.0000N/m3 The default value is 0.0000N/m3
6.4 Density	Floating points: 9999.99-0000.00kg/m3 The default is 1000. . 00kg/m3 Set the exact density when you need to use quality units!	
6.5 Language	Select item: Chinese English The default value is Chinese	

## 4.3 Parameter Settings

### 4.3.1 FLOW RATE



Press the key under the main display  to enter the instantaneous traffic settings interface.

#### 1, PV Units

- After selecting  the  applicable unit using the or key, press the key  to store the settings.

- Selectable units: L/s, L/m, L/h, m3/s, m3/m, m3/h, Nm3/s, Nm3/m, Nm3/h, USG/s, USG/m, USG/h, kg/s, kg/m, kg/h, t/s, t/m, t/h

#### 2, PV Decima

- After  selecting the  scale using the or key, press the key to store  the settings.





- You can select the number of numbers: 0,1,2,3

#### 3, Flow Range

- After setting  the  corresponding  value of 20mA with or , press the key to store  the setting.





Note: Scale **flow means that when the momentary** flow reaches this set value, the current output is **20mA**, and changing this parameter will **affect: current output, high and low flow alarm, etc.**

#### 4, Cut Off

- Use  or , key  to set the percentage you want to cut, and then press the  key to store the setting twice.

**Note: When the absolute value of the instantaneous traffic is less than the scale traffic × this set percentage, the instantaneous flow volume is 0.**

#### 5, High Alarm

- Use  or , key  to set the low flow alarm percentage, and then press the key to store  the setting.

Note: A high alarm signal is output when the absolute value of the momentary flow is greater than the scale flow  $\times$  this set percentage. This setting value must be the setting value of the low flow alarm percentage!

#### 6, Low Alarm

- Use  $\uparrow$  or  $\downarrow$  key  $\rightarrow$  to set the percentage of high flow alarm, then press the key to store  $\rightarrow$  the setting.

Note: A low alarm signal is output when the absolute value of the momentary flow is less than the scale flow  $\times$  this set percentage. This setting value must be the setting value of the high flow alarm percentage!

#### 7, Damping

- Use  $\uparrow$  or  $\downarrow$  key to set  $\rightarrow$  the damping time, and then press the key  $\rightarrow$  to store the setting.

Note: Defines the time constant for flow smoothing filtering, and the larger the flow, the more stable the flow, but the longer the response time.

### 4.3.2 TOTAL FLOW

Press the key under the main display  $\rightarrow$  screen to select the total  $\rightarrow$  amount  $\rightarrow$  settings interface with the or key.

#### 1, Total Units

- After selecting  $\rightarrow$  the  $\rightarrow$  applicable unit using the or key, press the key  $\rightarrow$  to store the settings.

- Selectable units: L, m<sup>3</sup>, N/m<sup>3</sup>, USG, kg, t

#### 2, Total Decimal

- After  $\rightarrow$  selecting the  $\rightarrow$  scale using the or key, press the key to store  $\rightarrow$  the settings.

- You can select the number of numbers: 0, 1, 2, 3

#### 3, Total Preset

- After setting  $\rightarrow$  the  $\rightarrow$  preset  $\rightarrow$  total using or , and then press the key to store the  $\rightarrow$  setting.

### 4.3.3 CALIBRATION

Press the key under the main display  $\rightarrow$  screen, then press the  $\rightarrow$  key, until the bottom line of the screen 4.000 or 20.000 appears, use or  $\rightarrow$  key to  $\rightarrow$  choose to enter the instrument correction interface.

#### 1, Loop Out Zero

- After setting  $\rightarrow$  the  $\rightarrow$  analog output  $\rightarrow$  correction value with or , press the key to store  $\rightarrow$  the setting.

- Set range: 3.0-5.0

**Note: Perform this function while measuring the 4-20mA current output with a precision current meter and input the reading into the meter, which automatically completes the calibration operation inside the meter.**

## 2, Loop Out Full

- After setting the analog output correction value with or , press the key to store the setting.

- Set range: 19.0-21.0

**Note: Perform this function while measuring the 4-20mA current output with a precision current meter and input the reading into the meter, which automatically completes the calibration operation inside the meter.**

## 4.3.4 OUTPUT

Under the main display, press the key to select the or key to enter the output settings interface.

### 1, Signal output

- After selecting the signal output using or , key, press the key to store the settings.

**Note: The converter directly outputs the measured sensor pulse signal, which can be used for instrument calibration**

### 2, Pulse output

- After selecting the equivalent output using or , the key, press the key to select the low/high level and set the relevant values, and then press the key to store the settings.

**Note: Effective high and low level, effective level pulse width(ms),pulse equivalent (range unit per pulse) can be set.**

### 3, Frequency output

- After selecting the equivalent output using or , key, press the key to set the relevant value, and then press the key to store the setting.

**Note: The space-to-air ratio is 50%, the frequency size is proportional to the flow, the maximum frequency can be set, and the maximum frequency corresponds to the set range flow.**

## 4.3.5 CONMMUNICATION



Press the key under the main display screen to select the access to the communication settings interface using the or key.

### 1, Mode



- After selecting the mode using the or key, press the key to store the settings.

- Selectable items:RTU,ASCII

## 2, Baud rate

- After selecting   the Baud rate using the or key, press the key  to store the settings. Baud rate (9600/19200/38400/57600).

## 3, Parity

- After using  the or key to select the  check method, press the key to store  the settings.
- Optional checks: EVEN ( parity), ODD (parity), NONE (no checks).

## 4, Device ID



- After setting  the device  address  using or , key, press the key to store the  setting. Device address (1-253).

### 4.3.6 FACTORY SETUP



Press the key under the main display,  or select the  key to  enter the factory parameter interface. (A secret code needs to be entered.)

100000)

#### 1, Sensor Size





- After selecting  the  sensor caliber using the or key, press the key to store  the settings.

#### 2, K-factor

- After setting  the  gauge factor using the or key, press the key  to store the setting.

**Note:** This parameter is determined at the time of the real flow calibration. This parameter is sensor-only and represents the characteristic value of the sensor.



#### 3, Linearity

- Use or ,  key to select a linear correction item and set the  appropriate value, then press the key to store the  settings.

#### 4, Density

- After setting  the  fluid density  with or , and then press the key to store the  setting.

#### 5, Language

- After  selecting the  language using the or key, press the key  to store the settings.

# V. Terminal Board Wiring Instructions

## 5.1 Terminal Schematic

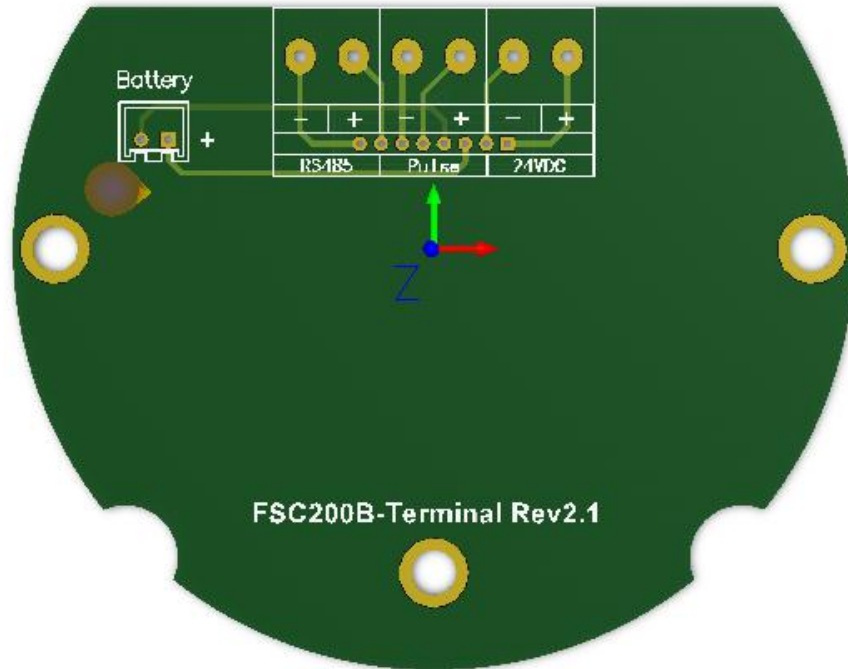

## 5.2 Terminal Board Wiring Instructions

Marked	Function	N	
24VDC	+	DC 18-36V Power	Power supply 24V plus
	-	DC 18-36V Power -	Power 24V-
<b>With a two-wire</b>			
Pulse	+	Frequency or pulse	The frequency or pulse output is passive
	-	Frequency or pulse	
RS485	+	RS485 Output . .	RS485 output
	-	RS485 Output -	

# Report:

## VI. RS485 Mailing Address Table

Variable address definition:

The name of the variable	Register address	first	Register length	The instruction code	The data type
Flow rate	0x01		0x02	0x04	Float
Flow rate units	0x03		0x01	0x04	int
Total	0x04		0x04	0x04	Double
Total units	0x08		0x01	0x04	int
Total (m3)	0x0d		0x02	0x03 0x04	Float
Flow rate	0x14		0x02	0x04	Float
Total	0x16		0x02	0x04	Float
Flow rate	0x1e		0x02	0x04	float inverse
Total	0x20		0x02	0x04	float inverse

Unit definition:

	Unit	Code
Flow rate	m3/h	0x03
	m3/m	0x04
	m3/s	0x05
	L/h	0x06
	L/m	0x07
	L/s	0x08
	usg/h	0x09
	usg/m	0x0a
	usg/s	0x0b
	kg/h	0x0c
	kg/m	0x0d
	kg/s	0x0e
	t/h	0x0f
	t/m	0x10
	t/s	0x11
Total	m3	0x01
	L	0x02
	usg	0x03
	kg	0x04
	T	0x05

## VII. Use and Adjustment

### 6.1 Precautions

- ◆ When using, keep the tested liquid clean and free of impurities such as fibers and particles.
- ◆ When the sensor starts to use, the sensor should be filled with liquid slowly, and then the outlet valve should be opened. It is strictly forbidden that the sensor is impacted by high-speed fluid when it is in a liquid-free state.
- ◆ The maintenance period of the sensor is generally half a year. During maintenance and cleaning, please be careful not to damage the parts in the measuring chamber, especially the impeller. When assembling, please pay attention to the position relationship between the guide and the impeller.
- ◆ When the sensor is not in use, the internal liquid should be cleaned, and protective sleeves should be added to both ends of the sensor to prevent dust from entering, and then stored in a dry place.
- ◆ The filter should be cleaned regularly when it is used. When not in use, the internal liquid should be cleaned, as with the sensor, with a dust cover, and stored in a dry place.
- ◆ Before the sensor is installed, connect the line with the display instrument, turn on the power, blow or turn the impeller by hand to quickly rotate it to observe whether there is display. When there is a display, install the sensor. If there is no display, check the relevant parts and troubleshoot.

### 6.2 Installation Location

**The pipe must be completely filled with liquid.** It is important to keep the pipeline completely filled with liquid at all times, otherwise the flow rate display will be affected, which may cause measurement errors.

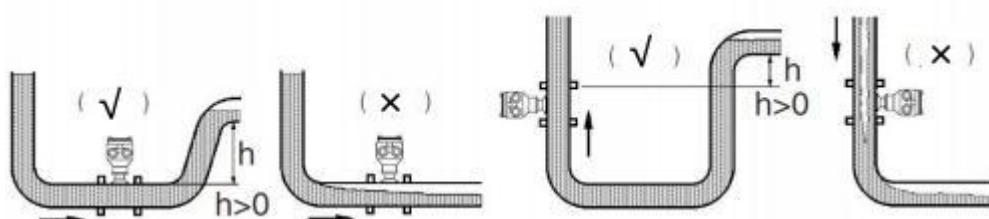

**Avoid air bubbles.** If air bubbles enter the measuring tube, the flow rate display may be affected, which may cause measurement errors.

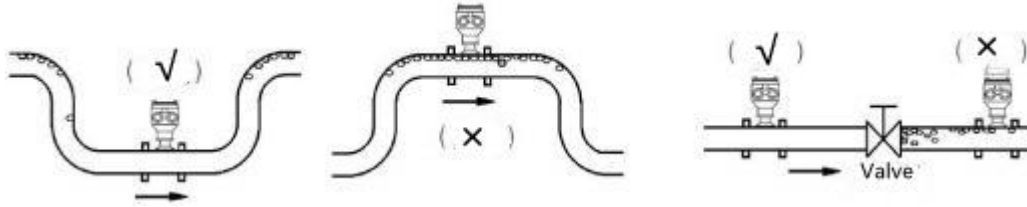

## VIII. Malfunction Repair

Fault phenomenon	Fault Analysis	Solution
There is flow, but the instantaneous flow is zero	1. Wiring error	Check meter wiring
	2. The internal parameters of the instrument are modified	Test instrument parameters in accordance with the verification certificate
	3. The signal acquisition coil is damaged, which affects the signal transmission, even if there is traffic passing through, the signal cannot be transmitted to the converter	Use a magnetic screwdriver to slide the signal acquisition coil
	4. Impeller jammed	Check impeller
No flow through the meter, instantaneous flow display	1. The pipe has severe vibration	It is recommended to add vibration reduction measures
	2. Whether the meter is well grounded	Check the grounding
	3. There are strong electromagnetic field interferences on site, such as inverters, motors, solenoid valves, etc. (50Hz power frequency interference on site. To a certain extent, it may affect the use of the instrument. The calculation of power frequency interference = $3600f/k$ , $f=50\text{Hz}$ , $k$ = Meter coefficient)	Through calculation, it can be judged whether the instrument has power frequency interference, and it is recommended to change the installation position.
	4. Meter pipe stop valve is not properly closed	Check Valve
Instrument normal measurement, measurement value is not accurate	1. The internal parameters of the instrument are faulty	Test instrument parameters according to verification certificate
	2. On-site pipelines are not required by symbols, contain gas or have high viscosity	Strictly operate in accordance with the installation instructions and precautions of the manual
The meter measures normally, the on-site LCD display is normal, and the meter current output is incorrect	3. The movement of the meter is in question, remove the meter and blow the impeller to run with the slider	In case of damage, contact the manufacturer

## **IX. Ordering Instruction**

1. When ordering the turbine flow sensor, the user should pay attention to selecting the appropriate specifications according to the nominal diameter of the fluid, working pressure, working temperature, flow range, fluid type and environmental conditions. When explosion-proof requirements are required, explosion-proof sensors must be selected, and the explosion-proof grade must be strictly observed.
2. When you need our company's display instrument matching, please refer to the corresponding manual and select the appropriate model, or our company's technical staff can design and select the model for you according to the information provided by you. Specify the specification length when you need a cable for signal transmission.